



ICC Evaluation Service, Inc.
www.icc-es.org

Business/Regional Office ■ 5360 Workman Mill Road, Whittier, California 90601 ■ (562) 699-0543
Regional Office ■ 900 Montclair Road, Suite A, Birmingham, Alabama 35213 ■ (205) 599-9800
Regional Office ■ 4051 West Flossmoor Road, Country Club Hills, Illinois 60478 ■ (708) 799-2305

Legacy report on the 1997 Uniform Building Code™

DIVISION: 03—CONCRETE
Section: 03410—Plant-Precast Structural Concrete

EPRI AUTOCLAVED AND NONAUTOCLAVED AERATED PRECISION BLOCKS AND ROOF AND FLOOR UNITS

ELECTRIC POWER RESEARCH INSTITUTE (EPRI)
POST OFFICE BOX 10412
PALO ALTO, CALIFORNIA 94303-0813

FLEXCRETE BUILDING SYSTEM, LC (FBS)
10653 SOUTH RIVER FRONT PARKWAY, SUITE 300
SOUTH JORDAN, UTAH 84095-3527

1.0 SUBJECT

EPRI Autoclaved and Nonautoclaved Aerated Precision Blocks and Roof and Floor Units.

2.0 DESCRIPTION

2.1 Precision Blocks:

2.1.1 General: EPRI Precision Blocks are solid, precast, noncombustible building units manufactured of autoclaved or nonautoclaved aerated concrete. The material is a lightweight concrete of a uniform cellular structure manufactured from a combination mixture of fly ash, quicklime and/or portland cement with aluminum powder, and cured in a high-pressure autoclave or through chemical process. Nonautoclaved aerated concrete also contains fibers. The amount and type of fibers are described in the quality control manual. The blocks are used for interior and exterior load-bearing and nonload-bearing walls.

The EPRI Precision Blocks are manufactured in two quality classes identified as 30 [which has a nominal dry density of 30 pcf (481 kg/m³)] and 35 [which has a nominal dry density of 35 pcf (561 kg/m³)]. The blocks are 24 inches (610 mm) in length and 8 inches (203 mm) in height, and are manufactured in thicknesses of 4 to 14 inches (102 to 356 mm), in 2-inch (51 mm) increments. The block tolerances are 1/8 inch (3 mm) for height, thickness and length.

EPRI Precision Blocks shall be laid with thin-joint mortar, which is available, along with the blocks, from the manufacturer (FBS). The thin-joint mortar is a proprietary mixture of portland cement adhesive and additives, and is supplied in a dry, ready-mixed form. The mortared joints shall be 1/8 inch (3 mm) thick and shall have a 28-day minimum

compressive strength of 1,000 pounds per square inch (6.9 MPa). The blocks shall be laid in a running bond with the vertical joints mortared.

2.1.2 Design: Structural design of walls constructed using the EPRI Precision Blocks shall be in accordance with the provisions of ACI 530/ASCE 5/TMS 402 or Section 2107 of the UBC, using the design values in Table 1 of this report.

2.1.3 Thermal Resistance: Thermal resistance properties of the EPRI Precision Blocks are indicated in Table 2.

2.1.4 Four-hour Fire-resistive-rated Limited Load-bearing Wall Assembly: The load-bearing wall shall be constructed of 8-inch-by-8-inch-by-24-inch (203 mm by 203 mm by 610 mm) EPRI Precision Blocks, in a running bond to a maximum height of 10 feet (3 m). The blocks shall be laid with the mortar as described in Section 2.1.1 of this report. The mortar joints shall be 1/8 inch (3 mm) thick, and the mortar shall be applied with a notched trowel. The trowel shall have notches that are 0.15 inch (3.8 mm) wide and 0.2 inch (5.1 mm) deep, spaced at 0.2-inch (5.1 mm) intervals. The wall must be limited to a maximum uniformly distributed axial load of 4,500 pounds per lineal foot (66 kN/m), concentrically located.

2.1.5 Miscellaneous: Walls below grade shall be built with EPRI Precision Blocks of quality class 35 only. To allow for the drying of the wall, either an impermeable membrane shall be installed on the exterior of the wall, thereby allowing for drying toward the interior; or a noncapillary air-permeable membrane shall be installed on the exterior, thereby allowing for drying toward the interior and exterior of the wall.

2.2 Roof and Floor Units:

2.2.1 General: EPRI precast units are available as structural floor and roof panels of quality class 35. The units are reinforced with smooth cold-drawn steel wires conforming to ASTM A 82. Transverse wires are welded to longitudinal reinforcement to provide additional mechanical anchorage. Reinforcing steel sizes range from W4 to W14 wires. All reinforcing wires are treated with a minimum 0.02-inch-thick (0.508 mm) anticorrosion coating. Reinforcing wire continues to the end of the slabs, and the minimum concrete cover for all bars is 1/2 inch (12.7 mm). The average moisture content of the units, at delivery, is approximately 30 percent by weight; the moisture dissipates gradually to equilibrium conditions. All metal connections, fasteners and accessories used to erect the units shall be manufactured from corrosion-resistant materials either compatible with the precast units or protected against corrosion.

*Corrected September 1, 2004

ICC-ES legacy reports are not to be construed as representing aesthetics or any other attributes not specifically addressed, nor are they to be construed as an endorsement of the subject of the report or a recommendation for its use. There is no warranty by ICC Evaluation Service, Inc., express or implied, as to any finding or other matter in this report, or as to any product covered by the report.



2.2.2 Design: The EPRI Roof and Floor Units shall be designed in accordance either with Appendix A—Alternate Design Method of Building Code Requirements for Reinforced Concrete (ACI 318-95), published by the American Concrete

Institute, or with Section 1926 of the 1997 *Uniform Building Code*[™] (UBC), with permissible service-load stresses as follows:

Extreme fiber stress in compression (f_c)	185 psi (1.28 MPa)
Shear stress with or without reinforcement (v_c)	11 psi (76 kPa)
Bearing stress (f_b)	140 psi (0.97 MPa)
Steel tensile stress (f_s)	26,000 psi (179 MPa)

These stresses shall be based on a specified compressive strength, f'_m , of the material, of 450 psi (3.1 MPa); a modulus of elasticity, E_c , of 250,000 psi (1724 MPa); and a yield stress of the reinforcement steel of 70,000 psi (448 MPa) in the finished product.

The roof and floor units have two layers of reinforcement, top and bottom, with a minimum $1/2$ -inch (12.7 mm) cover. Panels are manufactured with tongue-and-groove joints. (See Figure 1 for details.) All grooves are filled with a fine grout, having a portland-cement-to-sand ratio of 1:3. The maximum cantilevered panel lengths shall be limited to twice the panel thickness, unless specially reinforced units, and substantiating calculations, are provided to justify longer cantilevers. The calculations shall be submitted to the building official for approval.

All tensile steel is anchored by a minimum of two crossbars located within 8 inches (200 mm) of each end and spaced at least 3 inches (76 mm) apart; additional crossbars are spaced at intervals not exceeding 40 inches (1016 mm). For compressive steel, at least one crossbar is placed 4 inches (102 mm) from each end; additional crossbars are spaced at intervals not exceeding 40 inches (1016 mm). The crossbar steel shall be no smaller than one-third the area of the longitudinal steel.

Units having a span of up to and including 14 feet (4267 mm) shall have a minimum bearing of 2 inches (50.8 mm), or span/80, whichever is greater. Units having a span of more than 14 feet (4267 mm) shall have a minimum bearing of $2\frac{1}{2}$ inches (63.5 mm), or span/80, whichever is greater. Details of typical anchorage to structural steel are shown in Figure 2. (Typical details are for illustration purposes only, and shall be substantiated when used.) Anchorage stirrups shall be provided every second joint.

Approved roof coverings shall be used on the roof panels. Floor panels shall be protected from wetting and abrasion by an appropriate topping, to provide a wearing surface or base for tiles, linoleum, carpet, etc.

Tables 3 and 4 indicate allowable loads for roof and floor units of various spans and thicknesses.

2.2.3 Sound Reduction (Applicable to Only the Autoclaved Aerated EPRI Floor Units): The assembly which is shown in Figure 3 shall consist of 7.9-inch-thick (200 mm) EPRI Floor Units that have a nominal dry density of 34.3 pcf (550 kg/m³), with a structural plywood and a gypsum panel, connected to battens, laid over an isolation layer of mineral fiber above the floor units, and a ceiling gypsum panel, connected to battens, below the floor units.

A $3/4$ -inch-thick (19.1 mm) structural plywood panel, complying with UBC Standard 23-2, shall be installed above the 14-inch-thick (19.1 mm) gypsum board, complying with ASTM C 36, over 2-by-2 Douglas fir–larch battens, placed at 24 inches (609 mm) on center, perpendicular to the floor element. The timber battens shall float on the 1-inch (25.4 mm) layer of mineral fiber, which shall have a density of 2.2 pcf (36 kg/m³), and are not fixed to the floor unit.

The plywood panel shall be fixed through the gypsum board to the timber battens at 12 inches (305 mm) on center using No. 6 by 2.5-inch (63.5 mm) steel crosshead drywall self-tapping screws.

The timber under the floor unit shall be 2-by-2 Douglas fir–larch battens, placed at 24 inches (609 mm) on center, and shall be attached to the floor element using No. 12 by 3.5-inch (89 mm) slotted countersunk wood screws and Rawlplug fixings at 16-inch (406 mm) centers. The polypropylene fixings, referred to as “Rawlplug fixings” and manufactured by the Rawlplug Company Ltd., Glasgow, Scotland, United Kingdom, shall be set within a predrilled hole into the floor panel. The wood screws shall be screwed into the “Rawlplug fixings.”

The $1/2$ -inch-thick (12.5 mm) gypsum panel ceiling, complying with ASTM C 36, shall be fixed to the lower battens at 8-inch (203 mm) centers, using No. 6 by 1.25-inch (31.75 mm) steel cross head drywall self-tapping screws. The gypsum panels shall be installed with their long dimension perpendicular to the length of the battens.

The assembly attains a minimum sound transmission class (STC) of 50, and a minimum impact insulation class (IIC) of 50.

2.3 Installation:

The units shall be installed in accordance with this report and the approved construction drawings. A copy of the plans and this report shall be available at the jobsite at all times during installation. The instructions in this report shall govern if there are any conflicts between the manufacturer’s instructions and this report.

2.4 Fasteners:

Except as noted in Section 2.2.3, connectors and fasteners are beyond the scope of this report and are subject to approval by the building official for each project.

2.5 Special Inspection:

Special inspection of concrete, structural masonry and fastener placement shall conform to Section 1701.5 of the UBC. The special inspector’s duties include verifying panel, masonry unit and mortar identification; panel and unit placement; mortar preparation; and application.

2.6 Identification:

All panels produced in accordance with this report shall bear the name of the evaluation report holder (Electric Power Research Institute), the name of the manufacturer (Flexcrete Building Systems), the name of the inspection agency (Omega Point Laboratories), the production number, the strength class, and the evaluation report number (ER-5766).

Each cube or pallet of precision blocks produced in accordance with this report shall bear the name of the manufacturer (Flexcrete Building Systems), the strength class, the product number, and the evaluation report number (ER-5766).

Thin-joint mortar shall be identified with the product name, the manufacturer’s name (Flexcrete Building Systems) and address, the weight, the mixing instructions and the evaluation report number (ER-5766).

3.0 EVIDENCE SUBMITTED

Data in accordance with the ICC-ES Acceptance Criteria for Concrete and Concrete Masonry Wall Systems (AC15), dated October 1999; reports of tests for fire resistance in accordance with ASTM E 119; and reports for sound rating in accordance with ASTM E 90, ASTM E 419 and ASTM E 492.

4.0 FINDINGS

That the EPRI Autoclaved and Nonautoclaved Aerated Precision Blocks and Roof and Floor Units described in this report comply with the 1997 *Uniform Building Code*TM (UBC), subject to the following conditions:

- 4.1 Walls constructed using EPRI Precision Blocks are designed in accordance with ACI 530/ASCE 5/TMS 402 or Section 2107 of the UBC, using the allowable stresses noted in Table 1 of this report.
- 4.2 Roof and floor units are designed in accordance with ACI 318-95 and Section 1926 of the UBC, using the allowable stresses noted in Section 2.2.2 of this report.
- 4.3 All plans specifying the use of EPRI Precision Blocks and Roof and Floor Units are accompanied by structural design calculations, signed and sealed by a registered design professional.
- 4.4 The use of EPRI Precision Blocks as part of a fire-resistance-rated assembly is limited to the assembly described in Section 2.1.4 of this report.
- 4.5 During service, as well as prior to incorporation into the structure, EPRI Precision Blocks and Roof Units are protected from exposure to weather and against moisture intrusion. Evaluation of the weather-resistant exterior finish is beyond the scope of this report.
- 4.6 Inspection and installation of EPRI Roof and Floor Units complies with the requirements set forth in the UBC for precast concrete. Special inspection complies with Section 2.5 of this report.
- 4.7 Inspection and installation of EPRI Precision Blocks complies with the requirements set forth in the UBC for structural masonry. Special inspection complies with Section 2.5 of this report.
- 4.8 The EPRI blocks are manufactured at the FBS facility located in South Jordan, Utah, with inspections by Omega Point Laboratories (AA-657).

This report is subject to re-examination in two years.

TABLE 1

PROPERTY/ALLOWABLE STRESS	QUALITY CLASS	
	30	35
Compressive strength, f_m	320 psi	450 psi
Allowable shear stress	8 psi	11 psi
Allowable axial tensile stress	0 psi	0 psi
Allowable flexural tensile stress		
Parallel to bed joints	24 psi	34 psi
Normal to bed joints	18 psi	25 psi
Allowable bearing stress	107 psi	150 psi
Modulus of elasticity, E_m	150,000 psi	250,000 psi

For SI: 1 psi = 6.894 Pa.

TABLE 2

PROPERTY	QUALITY CLASS	
	30	35
Thermal resistance: R -value per inch of thickness	1.34	1.05
Thermal conductivity: U -value times thickness	0.74	0.95

For SI: 1 inch = 25.4 mm, 1 hr · ft²5F/Btu = 0.176110 m²@k/W.

TABLE 3—ROOF UNITS^{1,2,3,4} (24-INCH-WIDTH)

ALLOWABLE SUPERIMPOSED LOAD (psf)	THICKNESS (inches)	NORMAL LENGTH (feet)							
		8	10	12	14	16	18	20	22
25.0	4	X	X						
	6	X	X	X	X	X	X		
	8	X	X	X	X	X	X	X	X
	10	X	X	X	X	X	X	X	X
33.0	4	X	X						
	6	X	X	X	X	X			
	8	X	X	X	X	X	X	X	
	10	X	X	X	X	X	X	X	X
44.0	4	X	X						
	6	X	X	X	X	X			
	8	X	X	X	X	X	X	X	
	10	X	X	X	X	X	X	X	X
83.0	6	X	X	X					
	8	X	X	X	X	X			
	10	X	X	X	X	X	X	X	

For SI: 1 inch = 25.4 mm, 1 foot = 304.8 mm, 1 psf = 47.88 Pa, 1 pcf = 16.018 kg/m³.

X = panels are available.

¹Density is 33.8 pcf; compressive strength is 450 psi.

²All roof and floor units are designed for deflection of less than $1/360$ of span due to live loads, and less than $1/240$ of span due to live and dead load.

³Tolerances: Length \pm 0.20 inch

Width \pm 0.12 inch

Thickness \pm 0.12 inch

⁴The roof and floor slabs are designed only for dead weight and uniformly distributed downward superimposed loads. If uplift (wind) forces are encountered, further investigation is necessary to determine uplift load capacity.

TABLE 4—FLOOR UNITS^{1,2,3,4} (24-INCH-WIDTH)

ALLOWABLE SUPERIMPOSED LOAD (psf)	THICKNESS (inches)	NORMAL LENGTH (feet)						
		8	10	12	14	16	18	20
50	6	X	X	X				
	8	X	X	X	X	X		
	10	X	X	X	X	X	X	X
90	6	X	X	X				
	8	X	X	X	X	X	X	
	10	X	X	X	X	X	X	X

For SI: 1 inch = 25.4 mm, 1 foot = 304.8 mm, 1 psf = 47.88 Pa, 1 pcf = 16.018 kg/m³.

X = panels are available.

¹Density is 33.8 pcf; compressive strength is 450 psi.

²All roof and floor units are designed for deflection of less than $1/360$ of span due to live loads, and less than $1/240$ of span due to live and dead load.

³Tolerances: Length \pm 0.20 inch

Width \pm 0.12 inch

Thickness \pm 0.12 inch

⁴The roof and floor slabs are designed only for dead weight and uniformly distributed downward superimposed loads. If uplift (wind) forces are encountered, further investigation is necessary to determine uplift load capacity.

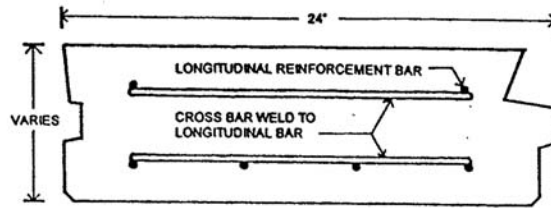

FIGURE 1—CROSS SECTION OF TYPICAL ROOF AND FLOOR UNITS

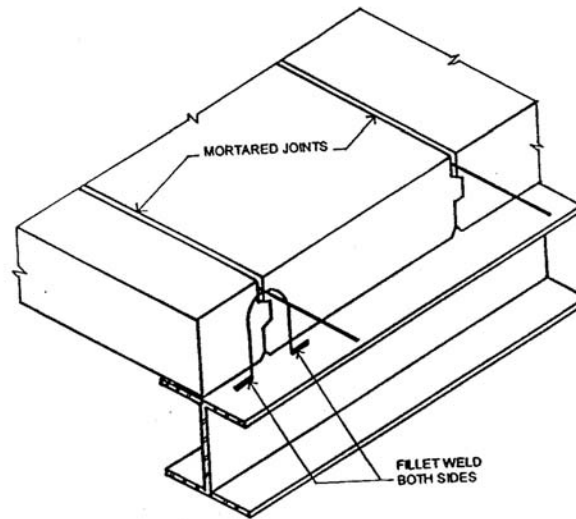
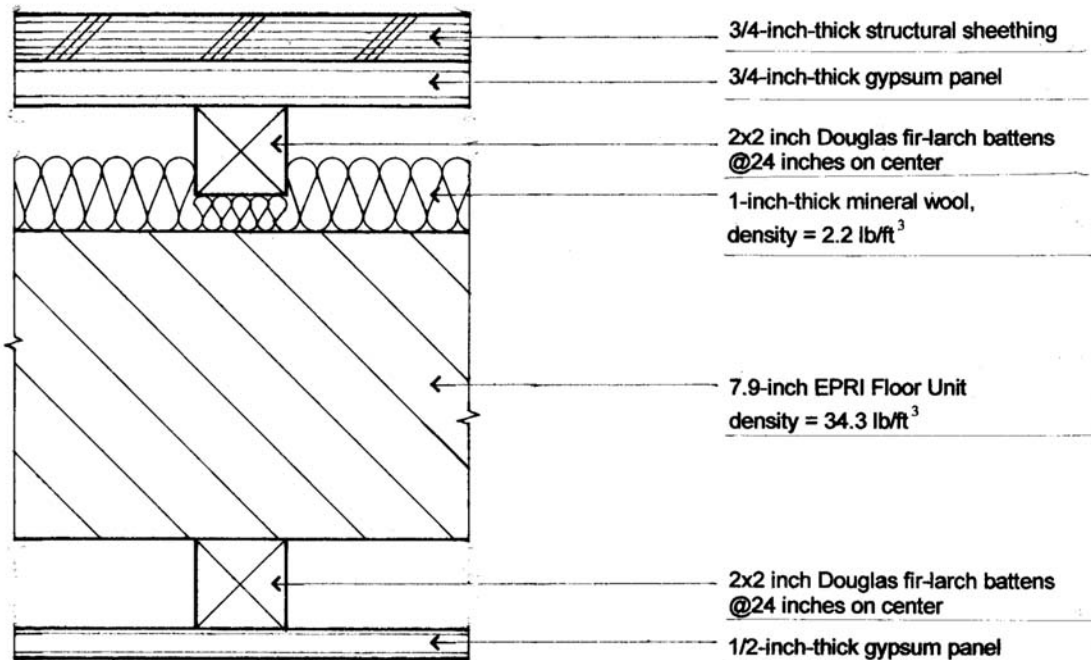

FIGURE 2—TYPICAL ANCHORAGE OF ROOF AND FLOOR UNITS TO STRUCTURAL STEEL FRAME



Not to Scale

FIGURE 3—SOUND REDUCTION ASSEMBLY
(This construction is only applicable to the autoclaved aerated EPRI Floor Units)